

Introduction

The FrSky RXSR-FC (OMNIBUS F4 Nano V7) uses the ICM20608 over SPI to produce stable flight performance. Integrated with the RXSR-FC receiver mounted onboard, and the ICM runs the 32k Gyro loop perfectly. Also onboard is an AB7456 OSD chip for the Betaflight OSD.

An on-board RXSR-FC receiver and 20mm x 20mm mounting holes make it perfect for a super clean micro quadcopter build. It supports 3-6S LiPo direct input and has 6 hardware UARTs and an I2C port.

Overview

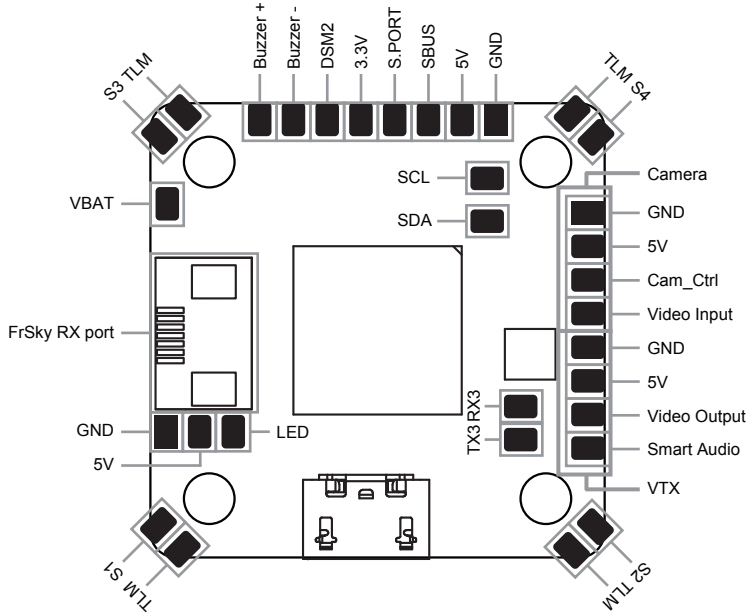

Specifications

- Tantalum Capacitors added for noiseless gyro reading
- Solder pads added for SmartAudio and Camera Control (next to Video pads)
- FPC port for FrSky FC receivers like the R9 MM-FC/RXSR-FC receiver
- This board now has 6 UART ports
- PWM pads on corner
- Upgraded BEC, 3A output

Features

- STM32 F405 MCU, Runs Betaflight firmware(supported from v3.2)
- ICM Gyro Over SPI Bus
- 20 x 20 mm Mounting holes
- Supports Lipo direct plugin (3-6S)
- Supports 5V 3A BEC output (Buck)
- STM32 controls OSD chip over SPI in DMA mode (Betaflight OSD)
- More UARTs

Resources

Function	Solder Pad Silk screen	Resources	MCU Pin	Notes
SBUS	SBUS	RX1	PA10	Build-in inverter
DSM2	TX1	TX1	PA9	CLI serialrx_halfduplex set to ON
Smart Audio VTX	S/A	TX5	PC12	
Smartport	S.P	UART 6	PC6/7	Build-in inverters
ESC Telemetry	TLM	RX2	PA3	
Camera Control	CC		PA8	
SDA	SDA	I2C1_SDA	PB9	
SCL	SCL	I2C1_SCL	PB8	
GPS	RX4/TX4	UART 4	PA0/1	
WS2812B LED	LED		PA15	
Buzzer	Bz-/Bz+		PC5	

FrSky is continuously adding features and improvements to our products. To get the most from your product, please check the download section of the FrSky website www.frsky-rc.com for the latest update firmware and manuals